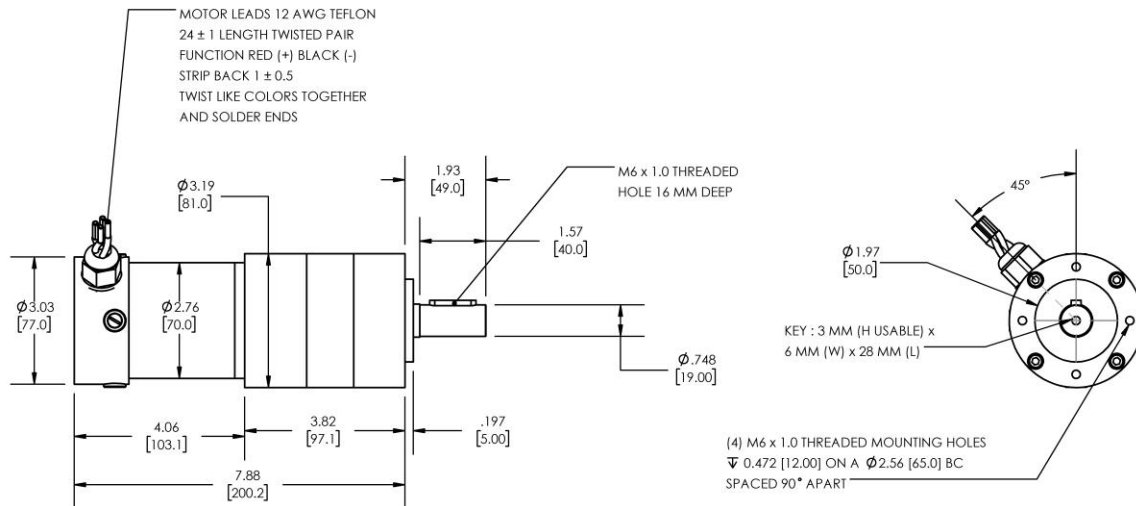

Model Number:
MMP S27-411F-36V GP81-04.3

DIMENSIONS ARE INCHES [MM] UNLESS OTHERWISE STATED

PLANETARY GEARMOTOR OUTPUT PARAMETERS:	VALUE	UNITS	TOLERANCE
Gearhead Ratio (exact)	4.28 : 1		
Gearhead Shaft Output Speed (at full-load)	920	RPM	MAX
Gearmotor Rated Continuous Torque	19	In-Lbs	MAX
Gearmotor Rated Peak Torque	137++	In-Lbs	----
Gearhead Standard Backlash	30	Arc Minutes	MAX
Gearhead Efficiency	80%	----	----
Output Shaft Radial Load Capacity	90	Lbs	MAX
Output Shaft Axial Load Capacity	18	Lbs	MAX
Gearmotor Total Weight	7.6	Lbs	MAX

++ All Peak Torque values are dependent upon duty. Contact our sales office for details.

DC MOTOR PERFORMANCE PARAMETERS:	VALUE	UNITS	TOLERANCE
Rated DC Voltage	36	DC VOLTS	----
Rated Continuous Current	9.94	AMPERES	----
No-Load Speed	4444	RPM	MAX
Rated Speed	3940	RPM	+/- 15%
Rated Continuous Power Out	259	WATTS	+/- 15%
Rated Continuous Torque	89	OZ-IN	----
Peak Torque (motor only)	639	OZ-IN	----
No-Load Current	1.83	AMPERES	MAX
Back EMF Constant (Ke)	8.1	V/KRPM	+/- 10%
Torque Constant (Kt)	11.0	OZ-IN/AMP	+/- 10%
DC Armature Resistance	0.41	OHMS	+/- 15%
Armature Inductance	0.30	mH	+/- 15%
Armature temperature	155	DEG. C	MAX

NOTES:

- ENCODER & BRAKE OPTIONS AVAILABLE – [FOLLOW THIS LINK FOR DETAILS](#)
- NEMA MOUNTING FLANGE OPTION AVAILABLE – [FOLLOW THIS LINK FOR DETAILS](#)

MIDWEST MOTION PRODUCTS

DESIGN, MANUFACTURING & DISTRIBUTION - MOTION CONTROL EQUIPMENT

www.midwestmotion.com

email: sales@midwestmotion.com